



Boost your immunotherapeutic research

Dynabeads® *ClinExVivo*™ CD3/CD28
Dynabeads® CD3/CD28





Dynabeads® *ClinExVivo*™ CD3/CD28

- Isolate, activate, and expand your T cells *ex vivo* with just one product
- Harvest 100–1,000-fold expanded T cells in just 9–14 days
- Recover T cells with properties comparable to *in vivo*–activated T cells

Dynabeads® *ClinExVivo*™ CD3/CD28 is the well-known product formerly known as Xcyte™ Dynabeads®, co-developed by Xcyte Therapies, Inc. and Dynal Biotech AS.

The ready-to-use Dynabeads® *ClinExVivo*™ CD3/CD28 are coated with covalently linked monoclonal antibodies directed against CD3/TCR and the co-stimulatory CD28 surface receptors that are required for optimal T cell expansion. The beads are designed to expand T cells in a manner that mimics what occurs *in vivo* upon activation via antigen-presenting cells. This method eliminates the need to maintain autologous antigen-presenting cells and antigen in culture, making it the most reproducible and reliable way to stimulate T cells. The covalent attachment of antibodies to paramagnetic beads allows for easy magnetic removal of beads and antibodies after T cell expansion. For scale-up, the Dynal *ClinExVivo*™ MPC® magnet has been developed for optimal performance with Dynabeads® *ClinExVivo*™ CD3/CD28.*

Evolution of T cell–based immunotherapy

Traditional methods for expanding T cells have often been cumbersome and complex, from both technical and regulatory points

of view. Cells often required culturing for a long period of time, ultimately exhibiting compromised biological activity such as loss of key surface receptors, reduced engraftment capabilities, and limited ability to recognize a broad range of antigens.

Dynabeads® *ClinExVivo*™ CD3/CD28 have been developed to maximize *ex vivo* T cell expansion while preserving T cell viability and optimal immunobiological properties. Small- and large-scale protocols have been developed for expanding T cells (Xcellerated T Cells™) in a variety of settings. Large-scale protocols using Dynabeads® *ClinExVivo*™ CD3/CD28 were developed utilizing cost- and labor-saving bioreactor systems capable of reproducibly generating $\geq 1 \times 10^{11}$ T cells in a single culture bag or reactor in under two weeks.

Intended use

Dynabeads® CD3/CD28 and Dynabeads® *ClinExVivo*™ CD3/CD28 are intended for *ex vivo* isolation, activation, and expansion of T cells in translational research.

* In the USA, a Device Master File for Dynabeads® *ClinExVivo*™ CD3/CD28 is on file with the Food and Drug Administration, and is available for cross-referencing within an approved IND or IDE application.

Get started with preclinical research

Dynabeads® CD3/CD28 is the research-grade version of Dynabeads® *ClinExVivo*™ CD3/CD28. The two products contain the same proportion of antibodies from the same clones.

The technology has been used extensively in research studies to evaluate the use of novel adoptive T cell transfer approaches to a number of disease states, as listed in Table 1. This research includes, expansion of polyclonal T cells from peripheral blood and cord blood (1,2), viral and tumor antigen-primed T cells (3), gene-modified/transduced T cells (4,5), marrow-infiltrating tumor-specific T cells (6), and regulatory T cells (7–12). It is particularly noteworthy that bead-activated T cells are easy to gene-modify with standard gene transduction systems. This unique portfolio of T cell expansion products creates new translational research opportunities.

Clinical research applications

As listed in Table 1, the Dynabeads® *ClinExVivo*™ CD3/CD28 technology has been used in a number of clinical investigations related to various disease states.

A number of immunobiological observations have been documented:

- In stem cell transplant settings with concurrent chemotherapy-induced lymphodepletion, infusion of polyclonal bead-activated and expanded T cells resulted in early T cell recovery, with both CD4⁺ and CD8⁺ T cell counts reaching normal levels within 5–10 days post-infusion
- After infusion of bead-activated and expanded autologous T cells, a majority of chronic lymphocytic leukemia (CLL) patients experienced a significant reduction in lymphadenopathy and splenomegaly
- In a number of clinical investigations, infused T cells were long-lived, and elevated T cell counts after infusion were maintained for at least one year

Table 1—A partial list of disease states in which T cells have been effectively isolated and expanded from patients, using the Dynabeads® *ClinExVivo*™ CD3/CD28 technology.

Disease state	T cell	Type of study	Reference
Autoimmune diseases	Autologous	Preclinical	13
Chronic lymphocytic leukemia (CLL)	Autologous or allogeneic	Phase I/II	14–16
Multiple myeloma (MM)	Autologous	Phase I/II	17–19
Non-hodgkins lymphoma (NHL)	Autologous or allogeneic	Phase I/II	20–22,15
Renal cell carcinoma (RCC)	Autologous	Phase I	23
Prostate cancer (PC)	Autologous	Phase I/II	24
Chronic myeloid leukemia (CML)	Autologous	Phase I	25
HIV infection	Autologous or gene-modified T cells	Phase I/II	26–32

Note: For research use. Not intended for any animal, human therapeutic, or diagnostic use, unless otherwise stated. In the USA, a Device Master File for Dynabeads® *ClinExVivo*™ CD3/CD28 is on file with the Food and Drug Administration, and is available for cross-referencing within an approved IND or IDE application.



Additional studies using bead-activated T cells are currently underway, including:

- Gene-modified CD19-specific (scFV) T cells to treat CLL
- Suicide gene-modified T cells (TK) to treat GVHD associated with donor lymphocyte infusion
- Autologous tumor vaccine-primed, bead-activated lymph node T cells to treat renal cell carcinoma (RCC)
- HER-2/neu tumor-peptide, vaccine-primed T cells to treat BC

Expanded T cells retain optimal immunobiological characteristics

Expansion of your T cells with Dynabeads® *ClinExVivo*™ CD3/CD28 will:

- Preserve the broadest antigen-recognition capabilities by maintaining T cell receptor repertoire during the expansion process for polyclonal T cells
- Enhance *in vivo* survival and homing potential by maintaining surface CD28 expression while inducing key homing receptors (e.g. L-selectin) and survival molecules (Bcl-XL)
- Preserve both cytolytic and T helper functions through the expansion of both CD4⁺ and CD8⁺ T cells

- Induce expression or secretion of a wide range of key immunomodulatory molecules including surface-bound CD40 ligand, CD137 (4-1BB), and cytokines such as IL-2, IFN γ , and TNF α
- Reverse T cell anergy and restore response to antigenic or mitogenic stimulation

The Dynabeads® expansion platform is shown in Figure 1.

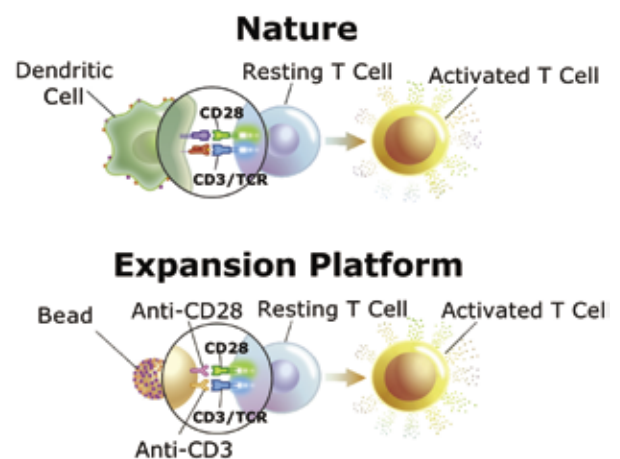

Figure 1—The Dynabeads® *ClinExVivo*™ CD3/CD28 *ex vivo* T cell expansion platform mimics *in vivo* expansion.

Scale up your research with the Dynal *ClinExVivo*[™] MPC[®] magnet

- Positively isolate bead-bound cells
- Deplete unwanted cell types
- Ideal for magnetic isolation in closed, sterile blood bags and tubing systems

The Dynal *ClinExVivo*[™] MPC[®] magnet (Figure 2) is a versatile magnetic separations device based on Dynabeads[®] technology and designed for medium- to large-scale cell separation in translational research (Figure 3).

- Scalable volumes: 50–330 ml in static separations, >10 L in continuous flow separations following T cell expansion protocols
- Residual beads that might escape initial magnetic capture are retained on a secondary magnet
- The magnetic platform can rotate 180° to optimize the capture process, reducing trapping of cells not captured by Dynabeads[®]

Intended use

The Dynal *ClinExVivo*[™] MPC[®] magnet is intended for use with the Dynabeads[®] *ClinExVivo*[™] products for translational research to positively isolate bead-bound cells:

- Positively isolate bead-bound cells (e.g., for subsequent stimulation or expansion of T cells with Dynabeads[®] *ClinExVivo*[™] CD3/CD28 and for removal of the beads following the expansion protocol).
- Deplete unwanted cell types by discarding the magnetically captured bead-bound cells (e.g. depletion of monocytes after phagocytosis of Dynabeads[®] *ClinExVivo*[™] Epoxy).

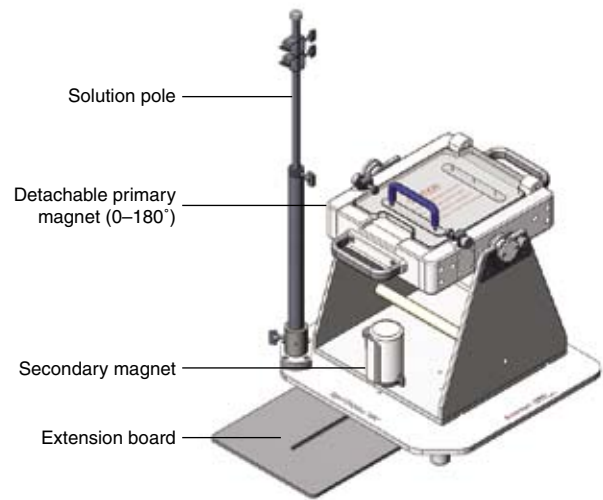

Figure 2—The Dynal *ClinExVivo*[™] MPC[®] magnet.

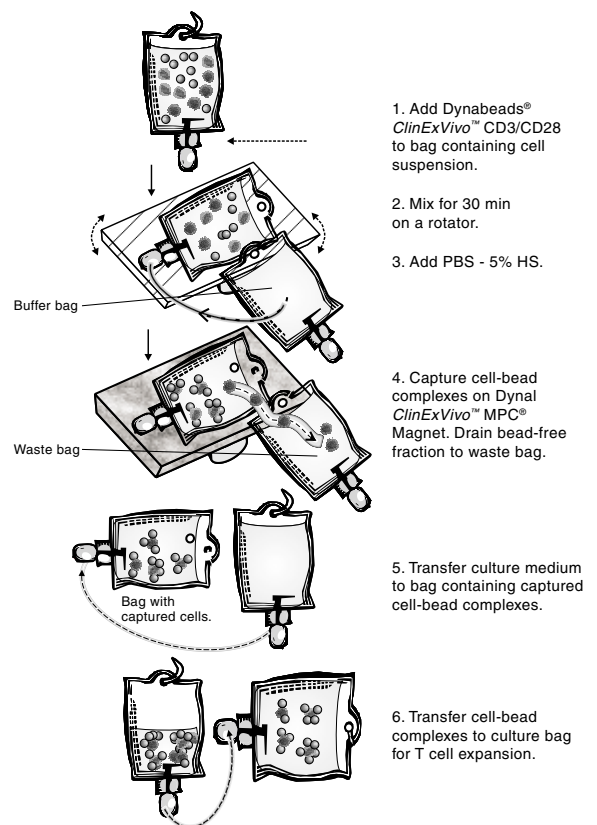

Figure 3—The Dynal *ClinExVivo*[™] MPC[®] magnet is ideal for large-scale magnetic separation.



Additional Dynabeads® *ClinExVivo*™ products—for flexible cell isolation

Two additional products are available for use with your own sterile antibodies for specific cell-type selection. Both products comply with ISO 9001:2001, ISO 13485:2003, and Medical Device Directive 93/42/EEC.

Dynabeads® *ClinExVivo*™ Sheep Anti-Mouse IgG are coated with polyclonal anti-mouse IgG antibodies. With the required IgG monoclonal antibody coupled to the beads, you can perform *ex vivo* isolation or depletion of any chosen cell type. Dynabeads® *ClinExVivo*™ Epoxy have activated epoxy groups on their surface. Unconjugated Dynabeads® *ClinExVivo*™ Epoxy can also be used to remove monocytes by direct phagocytosis of the *ClinExVivo*™ Epoxy beads.

Ordering information

Product	Quantity	Volume	Cat. no.
Dynabeads® <i>ClinExVivo</i> ™ CD3/CD28	4 × 10 ⁸ beads/ml	10 ml	402-03D
Dynabeads® CD3/CD28, research version of Dynabeads® <i>ClinExVivo</i> ™ CD3/CD28	1 × 10 ⁸ beads/ml	10 ml	111-41D
Dynabeads® <i>ClinExVivo</i> ™ Sheep anti-Mouse IgG	4 × 10 ⁸ beads/ml	10 ml	422-01
Dynabeads® <i>ClinExVivo</i> ™ Epoxy	4 × 10 ⁸ beads/ml	10 ml	402-01D
Dynal <i>ClinExVivo</i> ™ MPC®		1 unit	121-02

For current prices, please visit www.invitrogen.com.

References

1. Levine, B. L. et al. (1997) Effects of CD28 costimulation on long-term proliferation of CD4+ T cells in the absence of exogenous feeder cells. *J. Immunol.* 159:5921–5930.
2. Parmar, S. et al. (2006) Ex vivo expanded umbilical cord blood T cells maintain naïve phenotype and TCR diversity. *Cytotherapy* 8(2):149–157.
3. Kalamasz, D. et al. (2004). Optimization of Human T-Cell Expansion Ex Vivo Using Magnetic Beads Conjugated with Anti-CD3 and Anti-CD28 Antibodies. *J. Immunother.* 27:405–418.
4. Bondanza, A. et al. (2006) Suicide gene therapy of graft-versus-host disease induced by central memory human T lymphocytes. *Blood* Mar 1;107(5):1828–36.
5. Coito, S. et al. (2004) Retrovirus-mediated gene transfer in human primary T lymphocytes induces an activation-and transduction/selection-dependent TCRBV repertoire skewing of gene-modified cells. *Stem Cells Dev.* 13:71–81.
6. Noonan, K. et al. (2005) Activated marrow-infiltrating lymphocytes effectively target plasma cells and their clonogenic precursors. *Cancer Res.* 65:2026–2034.
7. Trenado, A. et al. (2006) Ex vivo-expanded CD4+CD25+ immunoregulatory T cells prevent graft-versus-host-disease by inhibiting activation/differentiation of pathogenic T cells. *J. Immunol.* Jan 15;176(2):1266–73.
8. Godfrey, W. R. et al. (2004) In Vitro Expanded Human CD4+CD25+ T Regulatory Cells can Markedly Inhibit Allogeneic Dendritic Cell Stimulated MLR Cultures. *Blood* 104:453–461.
9. Taylor, P. A. et al. (2004) L-Selectin(hi) but not the L-selectin(lo) CD4+25+ T-regulatory cells are potent inhibitors of GVHD and BM graft rejection. *Blood* 104(12):3804–12.
10. Tang, Q. et al. (2004) In Vitro-expanded Antigen-specific Regulatory T Cells Suppress Autoimmune Diabetes. *J. Exp. Med.* 199:1455–1465.
11. Godfrey, W. R. et al. (2005) Cord blood CD4+CD25+-derived T regulatory cell lines express FoxP3 protein and manifest potent suppressor function. *Blood* 105:750–758.
12. Earle, K. E. et al. (2005) In vitro expanded human CD4+CD25+ regulatory T cells suppress effector T cell proliferation. *Clin. Immunol.* 115:3–9.
13. Berenson, R. J. et al. (2003) Xcellerate Therapy: A Novel Therapeutic Strategy for the Treatment of Autoimmune Diseases. *Blood* November 16; 102 (11): Abstr. 839.
14. Bonyhadi, M. et al. (2005) In vitro engagement of CD3 and CD28 corrects T cell defects in chronic lymphocytic leukemia. *J. Immunol.* 174:2366–2375.
15. Porter, D. L. et al. (2006) A phase 1 trial of donor lymphocyte infusions expanded and activated ex vivo via CD3/CD28 costimulation. *Blood* Feb 15;107(4):1325–31.
16. Kipps, T. J. et al. A Phase I/II Study of Xcellerated T Cells™ in Patients with Chronic Lymphocytic Leukemia. Abstracts of the 2005 ASCO Annual Meeting; 13–15 May, 2005; Orlando, Florida, USA. Abstract 2511.
17. Rapoport A. P. et al. (2005) Restoration of immunity in lymphopenic individuals with cancer by vaccination and adoptive T-cell transfer. *Nat. Med.* Nov;11(11):1162–3.
18. Martin, T. et al. A Phase I/II Study of Xcellerated T Cells™ After Autologous Peripheral Blood Stem Cell Transplantation in Patients with Multiple Myeloma. Abstracts of the 2004 Tandem BMT Meetings; 13–17 February, 2004; Orlando, Florida, USA. Abstract 150132.
19. Berenson, J. R. et al. A Randomized Phase II Study of Xcellerated T Cells™ with or without Prior Fludarabine Therapy in Patients with Relapsed or Refractory Multiple Myeloma. Abstract #2410; *Blood* Volume 104, issue 11, November 16, 2004.
20. Fowler, D. et al. (2002) Phase I clinical trial of donor T-helper Type-2 cells after immunoablative, reduced intensity allogeneic PBSC transplant. *Cytotherapy* 4:429–430.
21. Laport, G. G. et al. (2003) Adoptive transfer of costimulated T cells induces lymphocytosis in patients with relapsed/refractory non-Hodgkin's lymphoma following CD34-selected hematopoietic cell transplantation. *Blood* 102:2004–2013.
22. Bartlett, N. L. et al. A Phase II Study of Xcellerated T Cells™ in Patients with Relapsed or Refractory Indolent Non-Hodgkin's Lymphoma (NHL). Abstract #4640; *Blood* Volume 104, issue 11, November 16, 2004.
23. Thompson, J. A. et al. (2003). A phase I trial of CD3/CD28-activated T cells (Xcellerated T cells) and interleukin-2 in patients with metastatic renal cell carcinoma. *Clin Cancer Res.* Sep 1;9(10 Pt 1):3562–70.
24. Glode, M. L. A phase I/II trial of CD3/CD28 activated T cells (Xcellerated T Cells) in patients with hormone refractory prostate cancer. Abstracts of the 2004 ASCO Annual Meeting; 5–8 June, 2004; New Orleans, LA, USA. Abstract 2549.
25. Rapoport, A. P. et al. (2004) Molecular remission of CML after autotransplantation followed by adoptive transfer of costimulated autologous T cells. *Bone Marrow Transpl.* 33:53–60.
26. Deeks, S. G. et al. (2002) A Phase II Randomized Study of HIV-Specific T-Cell Gene Therapy in Subjects with Undetectable Plasma Viremia on Combination Antiretroviral Therapy. *Mol. Ther.* 5:788–797.
27. Mitsuyasu, R. T. et al. (2000) Prolonged survival and tissue trafficking following adoptive transfer of CD4zeta gene-modified autologous CD4(+) and CD8(+) T cells in human immunodeficiency virus-infected subjects. *Blood* 96:785–793.
28. Levine, B. L. et al. (2002) Adoptive transfer of costimulated CD4+ T cells induces expansion of peripheral T cells and decreased CCR5 expression in HIV infection. *Nat. Med.* 8:47–53.
29. Humeau, L. M. et al. (2004) Efficient lentiviral vector-mediated control of HIV-1 replication in CD4 lymphocytes from diverse HIV+ infected patients grouped according to CD4 count and viral load. *Mol. Ther.* Jun;9(6):902–13.
30. Levine, B. L. et al. (1998) Large-scale production of CD4+ T cells from HIV-1 infected donors after CD3/CD28 costimulation. *J. Hematother.* 7:437–448.
31. Carroll, R. G. et al. (1997) Differential regulation of HIV-1 fusion cofactor expression by CD28 costimulation of CD4+ T cells. *Science* 276:273–276.
32. Levine, B. L. et al. (1996) Antiviral effect and ex vivo CD4+ T cell proliferation in HIV-positive patients as a result of CD28 costimulation. *Science* 272:1939–1943.

Legal and Regulatory

Dynabeads® *ClinExVivo*™ CD3/CD28 complies with ISO 9001:2000, ISO 13485:2003, and Medical Device Directive 93/42/EEC.

These products may be covered by one or more Limited Use Label Licenses (see the Invitrogen catalog or www.invitrogen.com). By use of these products you accept the terms and conditions of all applicable Limited Use Label Licenses. For research use. Not intended for any animal, human therapeutic, or diagnostic use, unless otherwise stated. A Device Master File is held with the United States Food and Drug Administration (FDA) for cross-referencing in IND and IDE applications. If cross-referencing, and the Device Master File is of interest for an Investigational New Drug application or other application, please contact Invitrogen with sponsor's and/or investigators full name and address, along with the project name and aim. This information is required by Invitrogen to issue a Letter of Authorization to inform the FDA who has been authorized to cross-reference the Device Master File

Dynal®, Dynabeads®, and Dynal MPC® are registered trademarks and *ClinExVivo*™, Xcyte™, Xcyte Therapies™, Xcellerate™, and Xcellerated T Cells™ are trademarks of Invitrogen. The Dynabeads® products and their applications are protected by several international patents and patent applications.

